

# Chapter 22

## Gauss's Law

PowerPoint® Lectures for  
*University Physics, Thirteenth Edition*  
– *Hugh D. Young and Roger A. Freedman*

Lectures by Wayne Anderson

# Goals for Chapter 22

---

- To use the electric field at a surface to determine the charge within the surface
- To learn the meaning of electric flux and how to calculate it
- To learn the relationship between the electric flux through a surface and the charge within the surface
- To use Gauss's law to calculate electric fields
- To learn where the charge on a conductor is located

# Introduction

---

- Would the girl's hair stand on end if she were inside the metal sphere?
- Symmetry properties play an important role in physics.
- Gauss's law will allow us to do electric-field calculations using symmetry principles.

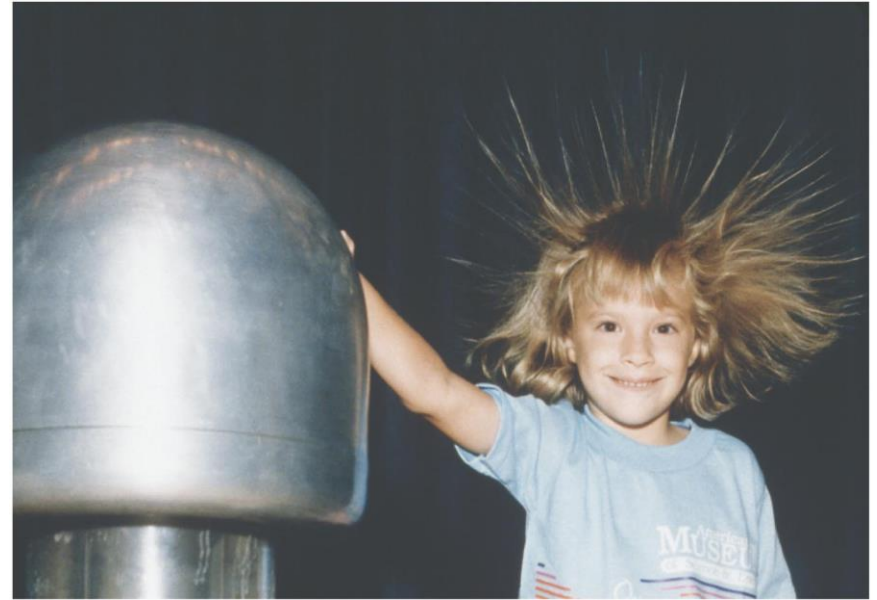

# Charge and electric flux

- Positive charge within the box produces outward *electric flux* through the surface of the box, and negative charge produces inward flux. (See Figure 22.2 below.)

(a) Positive charge inside box, outward flux

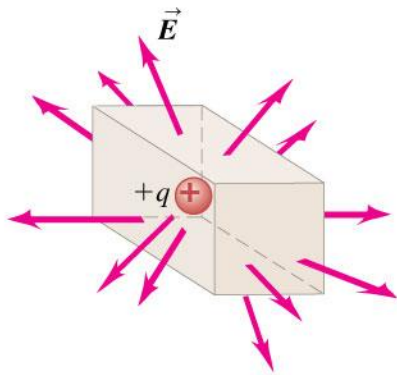

(b) Positive charges inside box, outward flux

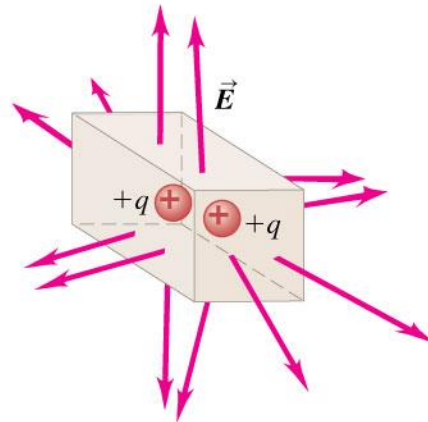

(c) Negative charge inside box, inward flux

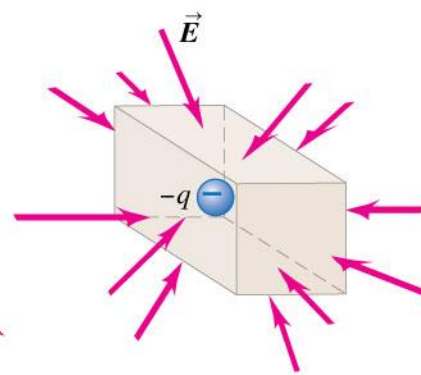

(d) Negative charges inside box, inward flux

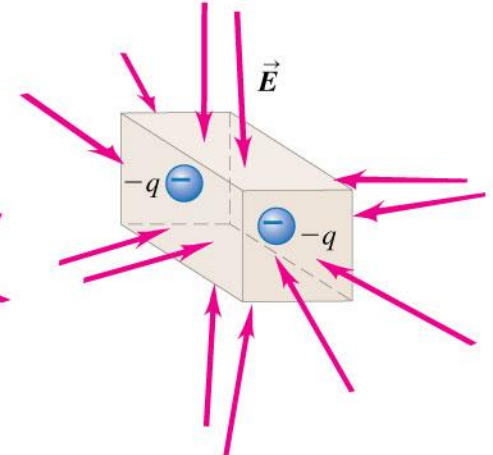

# Zero net charge inside a box

- Figure 22.3 below shows three cases in which there is zero *net* charge inside a box and no net electric flux through the surface of the box.

(a) No charge inside box,  
zero flux

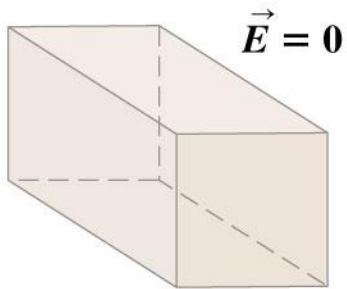

(b) Zero *net* charge inside box,  
inward flux cancels outward flux.

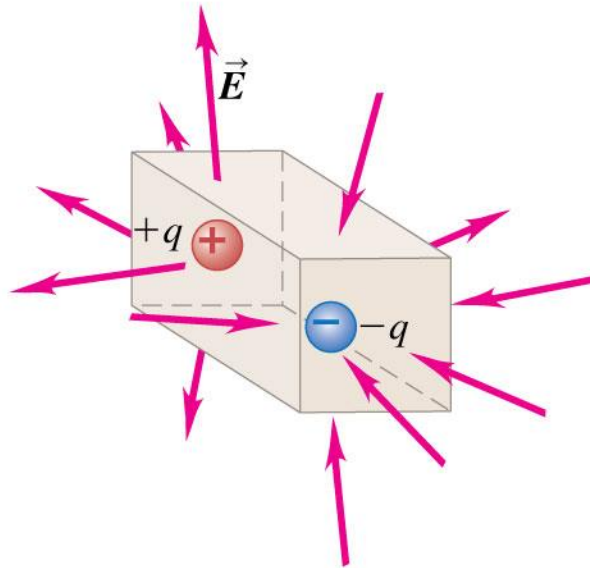

(c) No charge inside box,  
inward flux cancels outward flux.

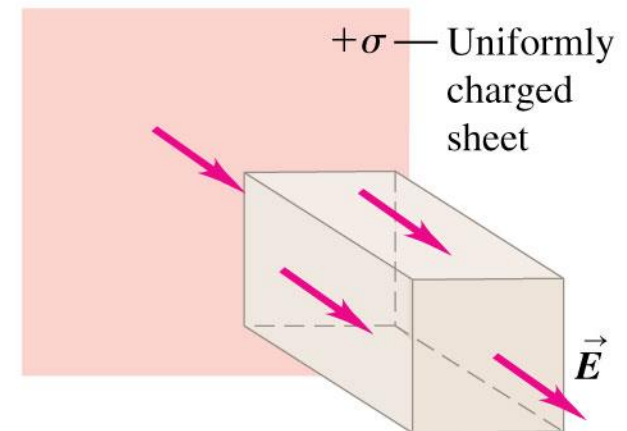

# What affects the flux through a box?

- As Figure 22.4 below shows, doubling the charge within the box doubles the flux, but doubling the size of the box does not change the flux.
- Follow the discussion of charge and flux in the text.

(a) A box containing a charge

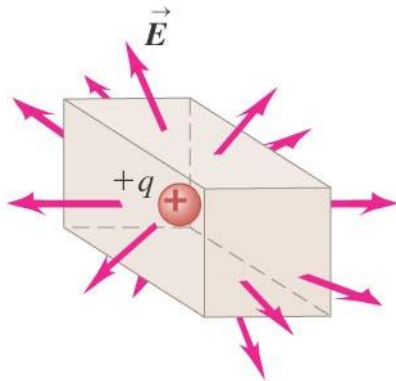

(b) Doubling the enclosed charge doubles the flux.

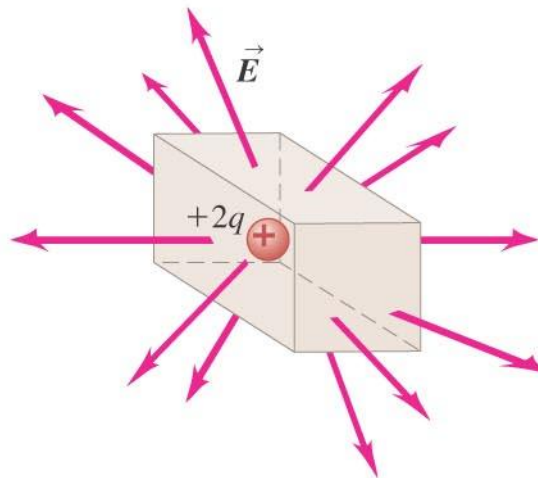

(c) Doubling the box dimensions does not change the flux.

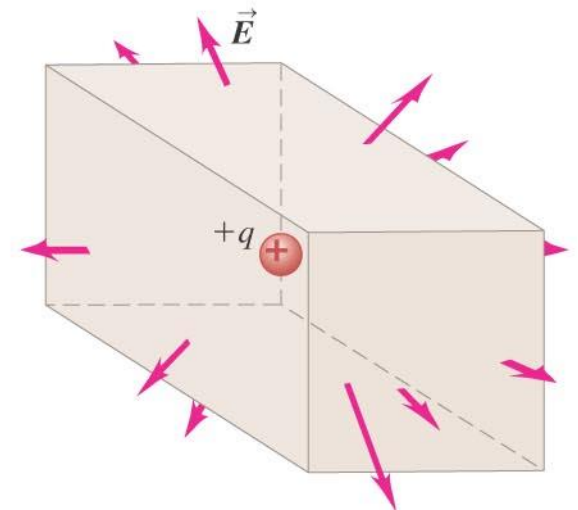

# Calculating electric flux

- Follow the discussion in the text of flux calculation for uniform and nonuniform fields, using Figure 22.6 below.

(a) Surface is face-on to electric field:

- $\vec{E}$  and  $\vec{A}$  are parallel (the angle between  $\vec{E}$  and  $\vec{A}$  is  $\phi = 0$ ).
- The flux  $\Phi_E = \vec{E} \cdot \vec{A} = EA$ .

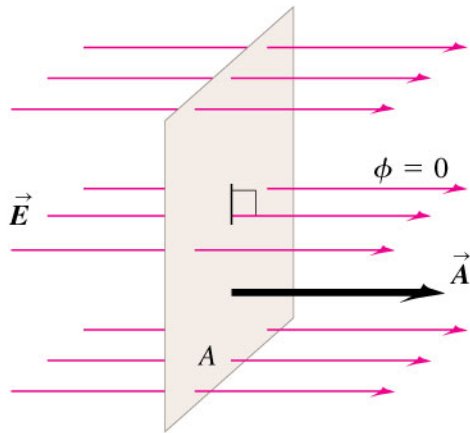

(b) Surface is tilted from a face-on orientation by an angle  $\phi$ :

- The angle between  $\vec{E}$  and  $\vec{A}$  is  $\phi$ .
- The flux  $\Phi_E = \vec{E} \cdot \vec{A} = EA \cos \phi$ .

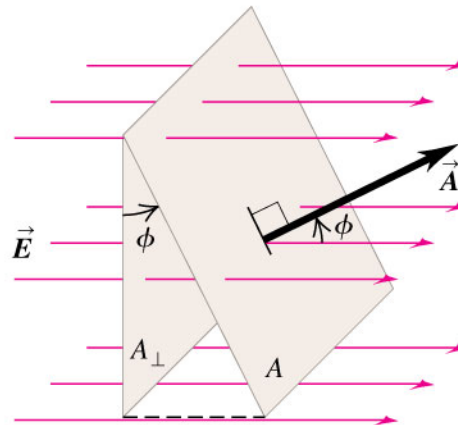

(c) Surface is edge-on to electric field:

- $\vec{E}$  and  $\vec{A}$  are perpendicular (the angle between  $\vec{E}$  and  $\vec{A}$  is  $\phi = 90^\circ$ ).
- The flux  $\Phi_E = \vec{E} \cdot \vec{A} = EA \cos 90^\circ = 0$ .

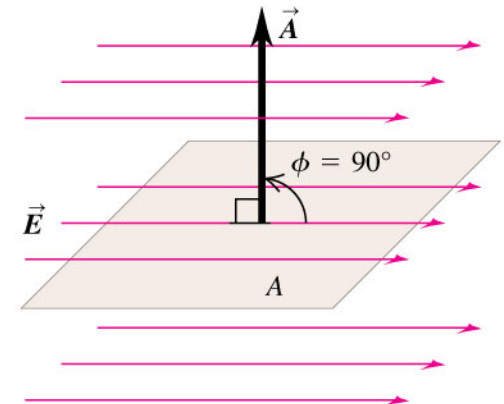

# Electric flux through a disk

- Follow Example 22.1 to evaluate flux through a disk. Use Figure 22.7 below.

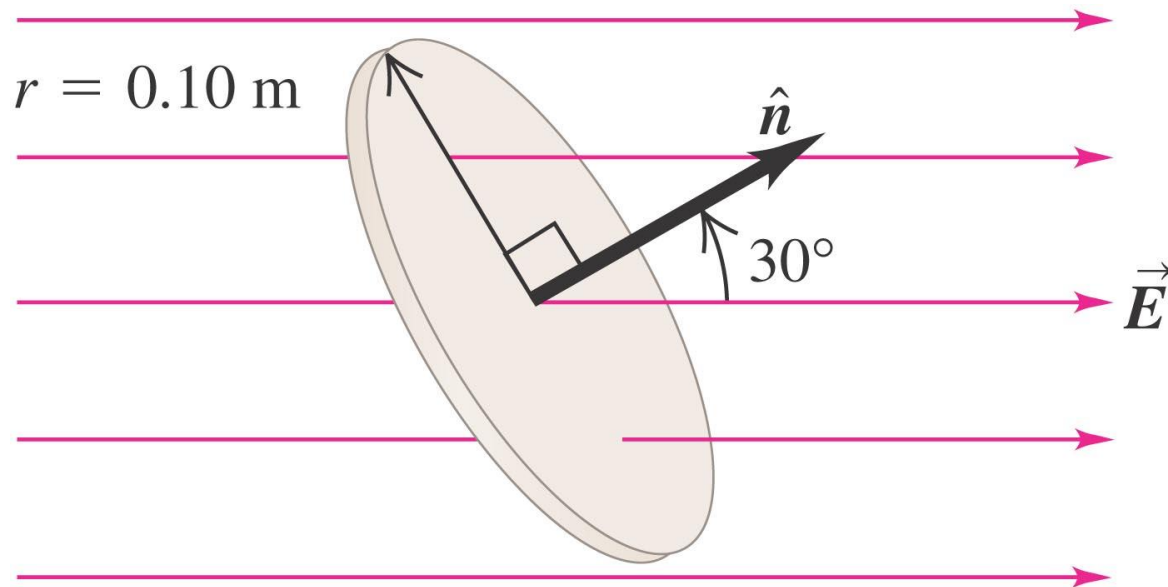



# Electric flux through a cube

- Follow Example 22.2 to evaluate flux through a cube using Figure 22.8 below.

(a)

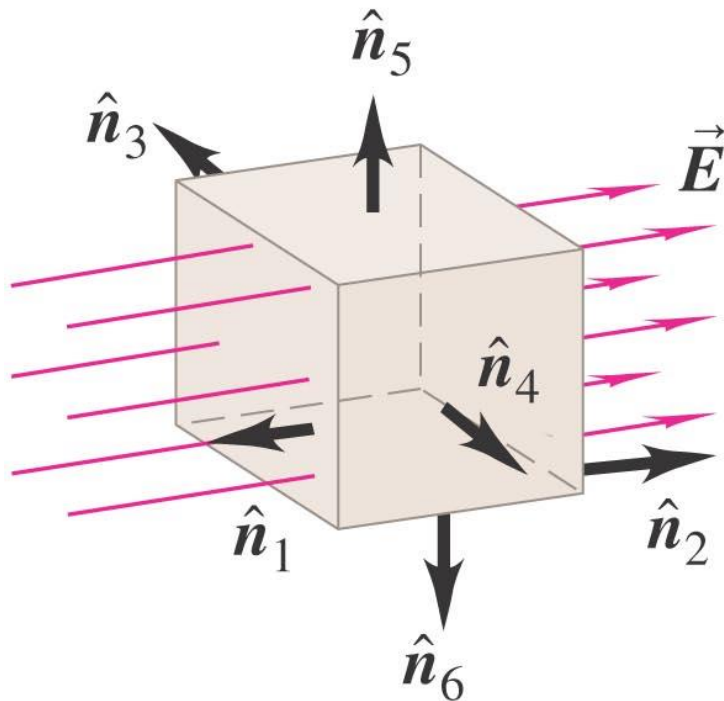

(b)

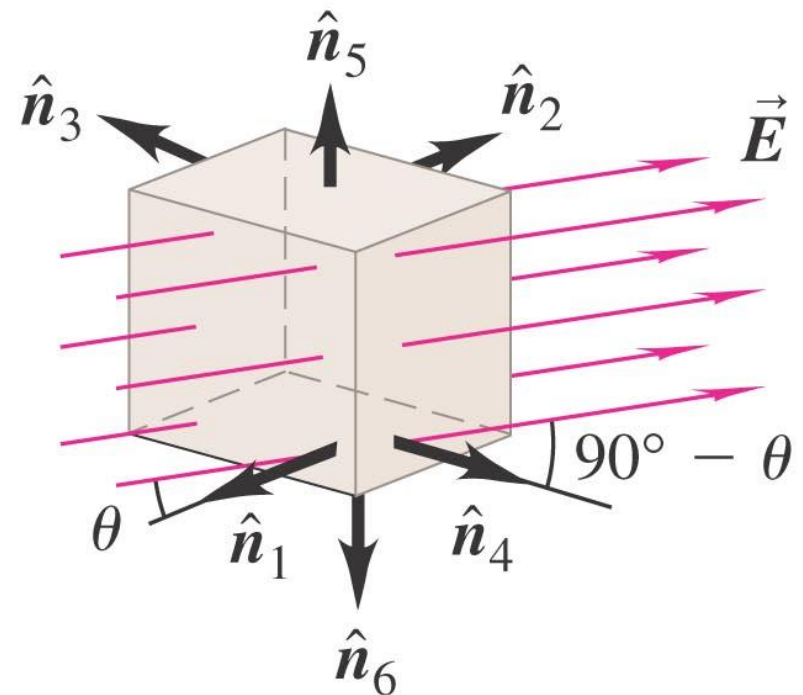

# Electric flux through a sphere

- Follow Example 22.3 to evaluate flux through a disk. Use Figure 22.9 below.

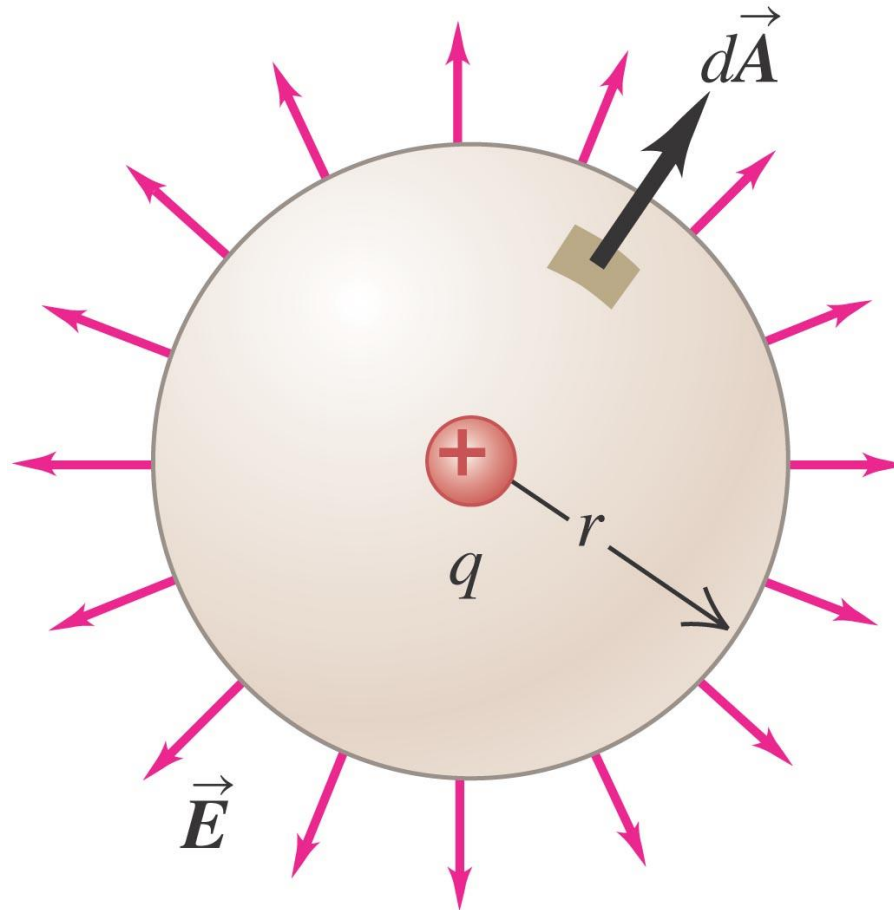

# Gauss's Law

---

- Gauss's law is an alternative to Coulomb's law and is completely equivalent to it.
- Carl Friedrich Gauss, shown below, formulated this law.



# Point charge centered in a spherical surface

- The flux through the sphere is independent of the size of the sphere and depends only on the charge inside. Figure 22.11 at the right shows why this is so.

The same number of field lines and the same flux pass through both of these area elements.

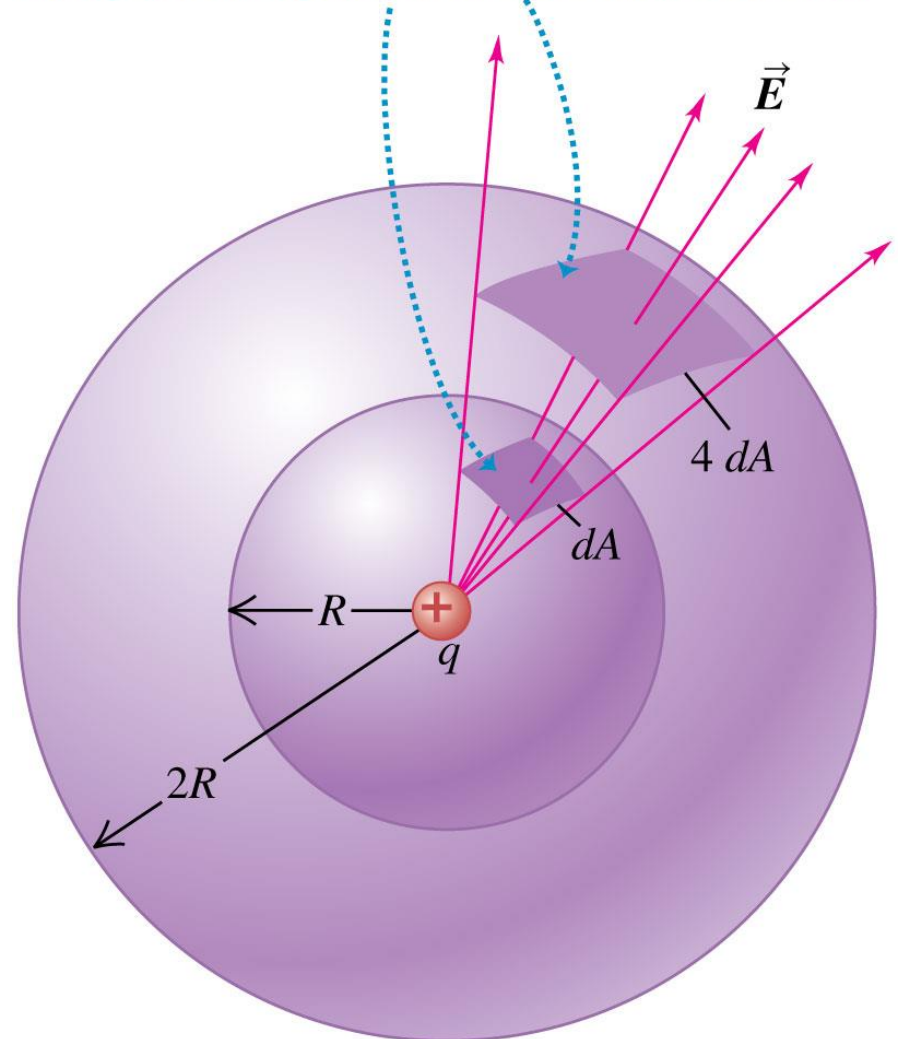

# Point charge inside a nonspherical surface

- As before, the flux is independent of the surface and depends only on the charge inside. (See Figure 22.12 below.)

(a) The outward normal to the surface makes an angle  $\phi$  with the direction of  $\vec{E}$ .

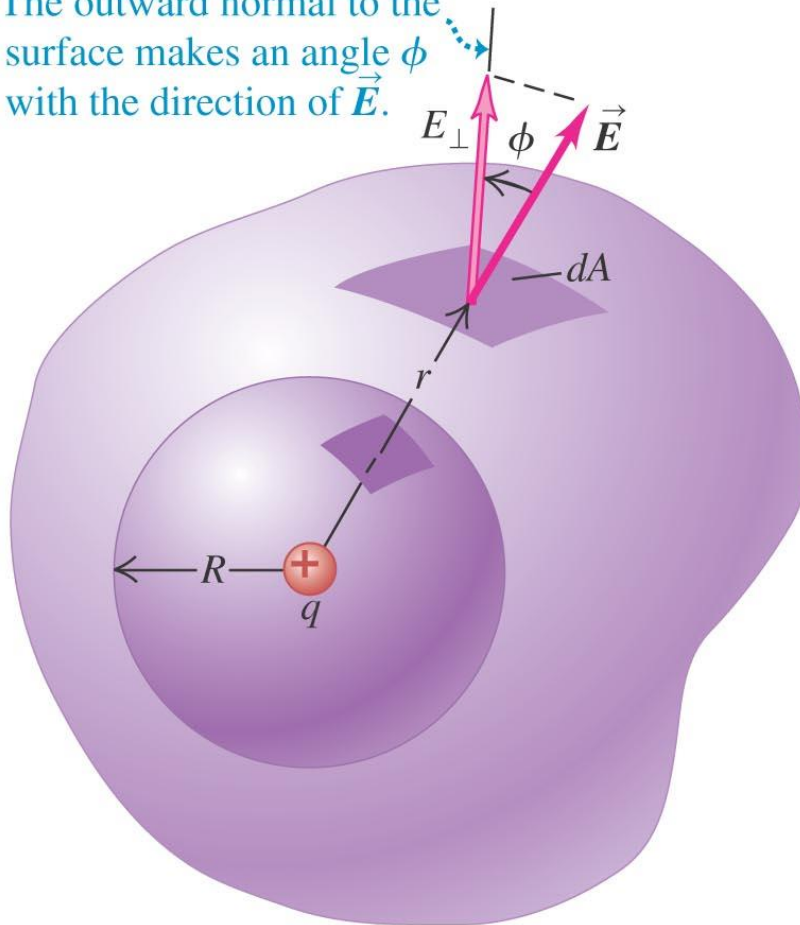

(b)

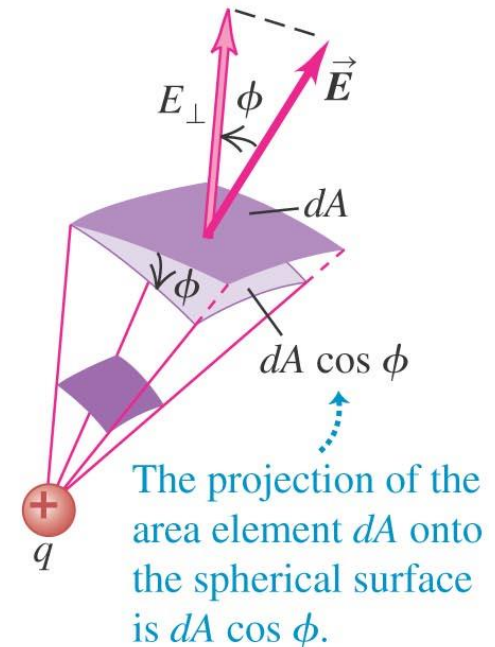

# Positive and negative flux

- Figure 22.14 below shows that flux is positive if the enclosed charge is positive, and negative if the charge is negative.

(a) Gaussian surface around positive charge:  
positive (outward) flux

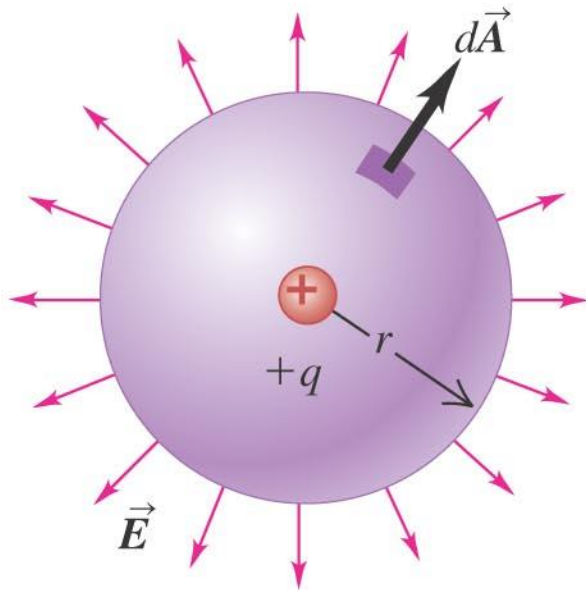

(b) Gaussian surface around negative charge:  
negative (inward) flux

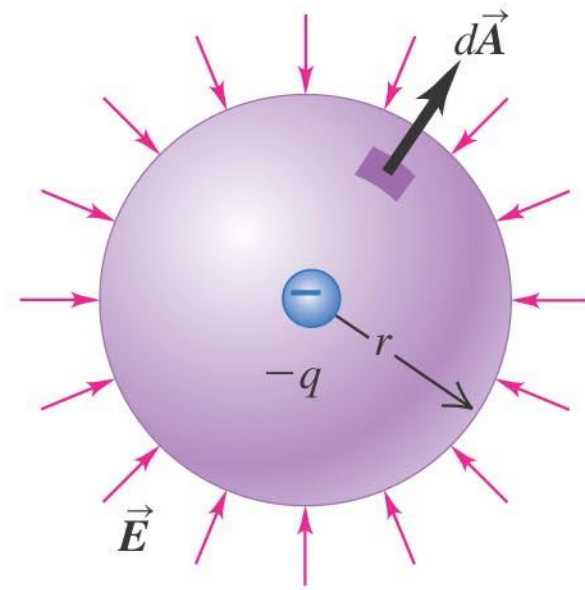

# General form of Gauss's law

- Follow the text discussion of the general form of Gauss's law.
- Follow Conceptual Example 22.4 using Figure 22.15 below.

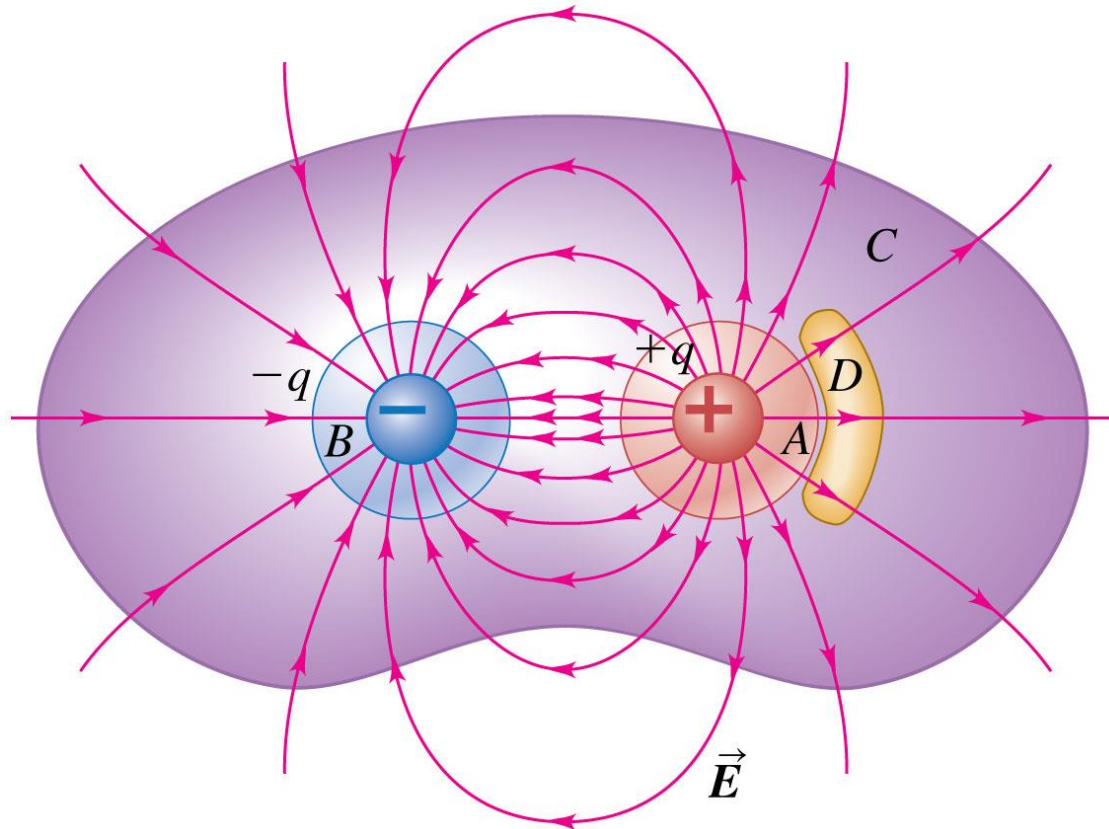

# Applications of Gauss's law

- Under electrostatic conditions, any excess charge on a conductor resides entirely on its *surface*. (See Figure 22.17 below left.)
- Follow Example 22.5 using Figure 22.18 below right.

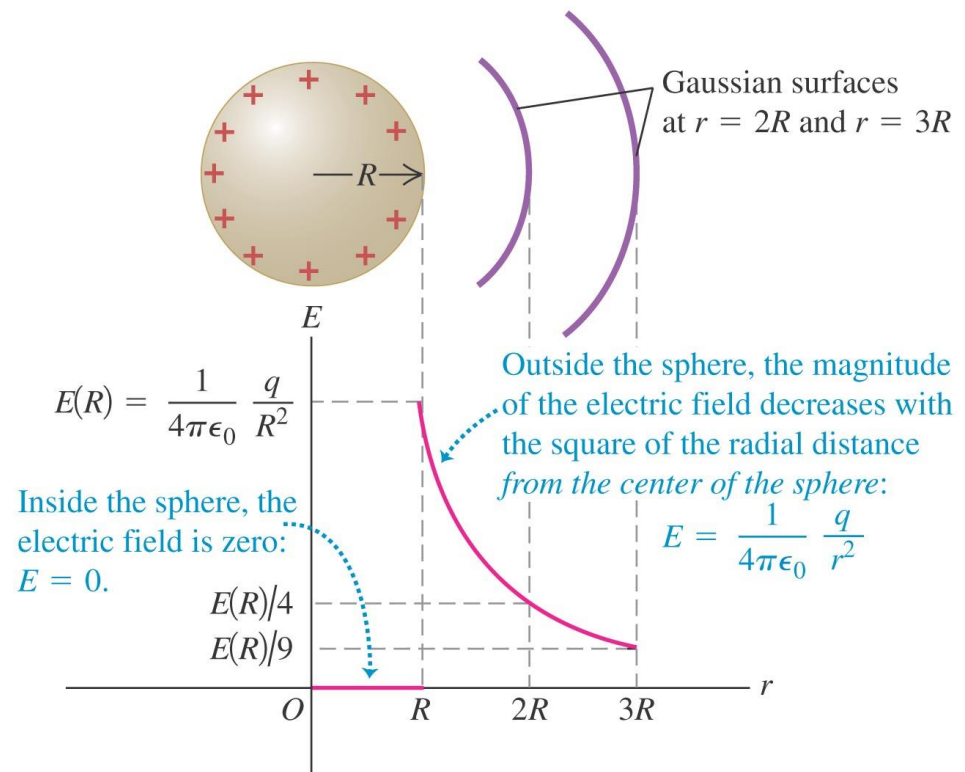
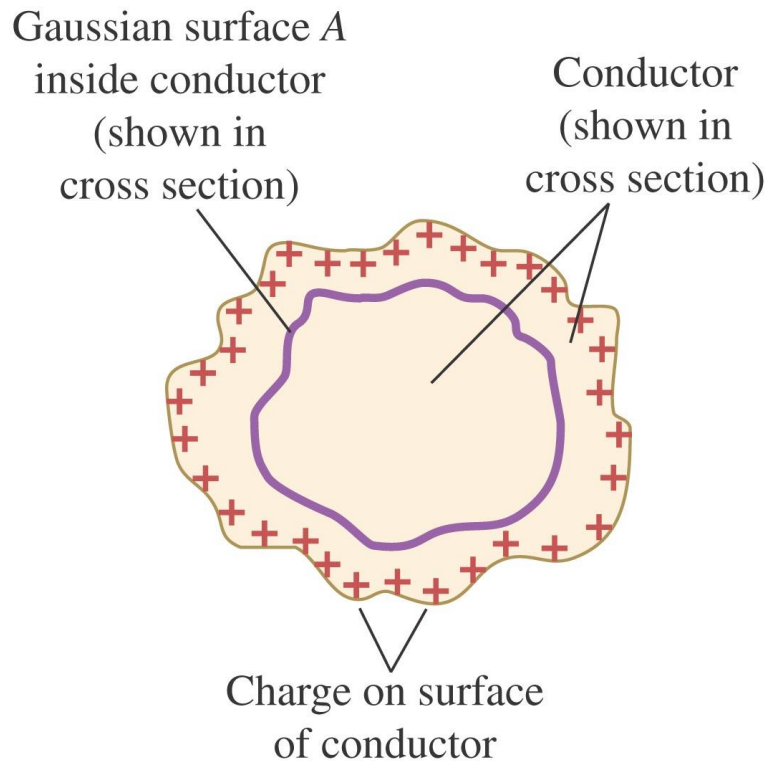



# Field of a line charge

- Follow Example 22.6 using Figure 22.19 below, for a uniform line charge.

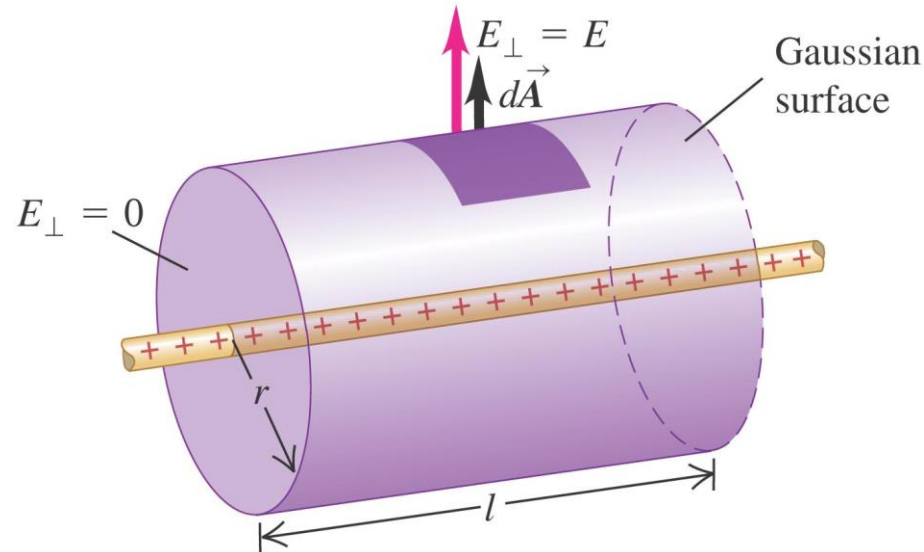

# Field of a sheet of charge

- Follow Example 22.7 using Figure 22.20 below, for an infinite plane sheet of charge.

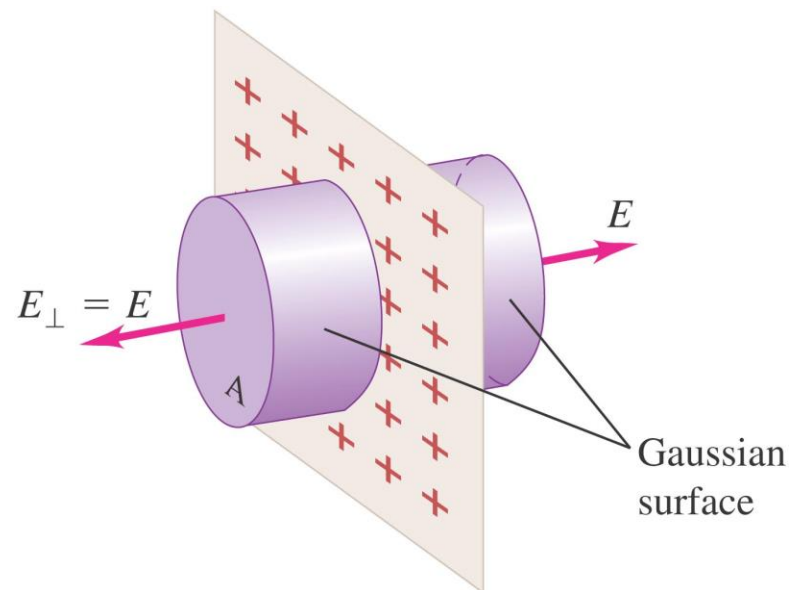

# Field between two parallel conducting plates

- Follow Example 22.8 using Figure 22.21 below for the field between oppositely charged parallel conducting plates.

(a) Realistic drawing

Between the two plates the electric field is nearly uniform, pointing from the positive plate toward the negative one.

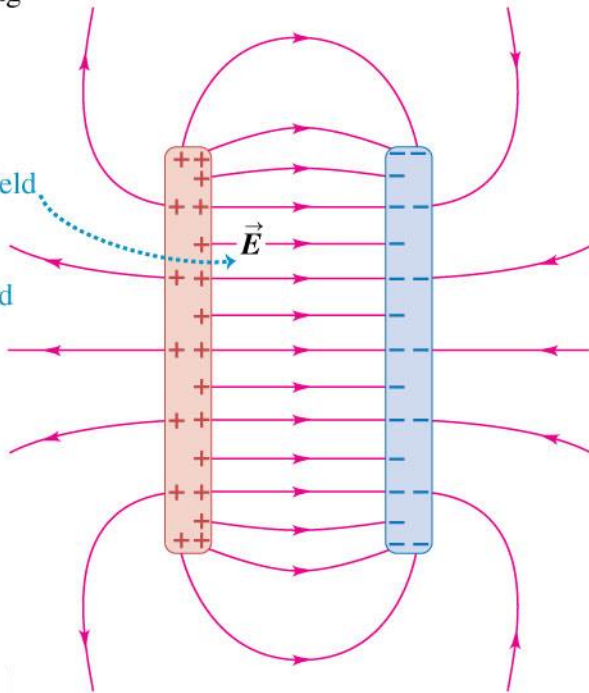

(b) Idealized model

In the idealized case we ignore “fringing” at the plate edges and treat the field between the plates as uniform.

Cylindrical Gaussian surfaces (seen from the side)

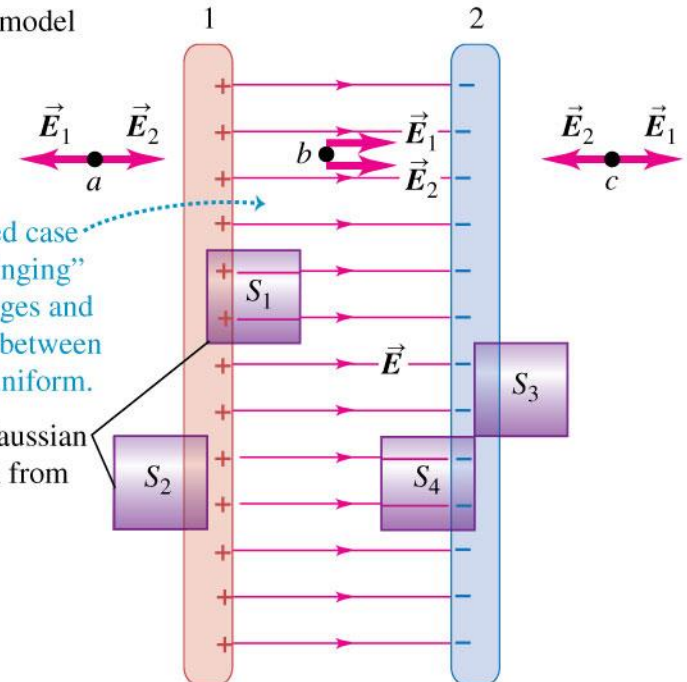

# A uniformly charged sphere

- Follow Example 22.9 using Figure 22.22 below, for the field both inside and outside a sphere uniformly filled with charge.
- Follow Example 22.10 for the charge on a hollow sphere.

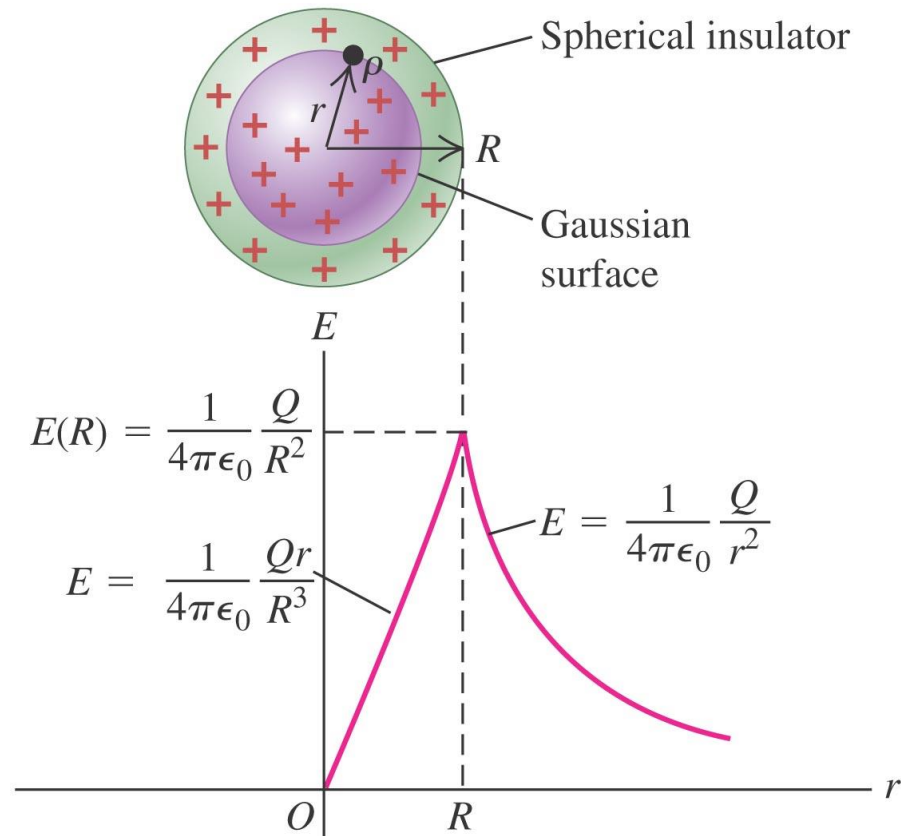

# Charges on conductors

- In the text, follow the discussion on charges in a conductor having a cavity within it. Figure 22.23 below will help the explanation.

(a) Solid conductor with charge  $q_C$

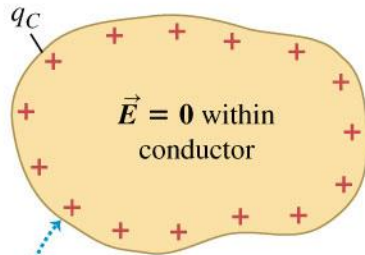

The charge  $q_C$  resides entirely on the surface of the conductor. The situation is electrostatic, so  $\vec{E} = 0$  within the conductor.

(b) The same conductor with an internal cavity

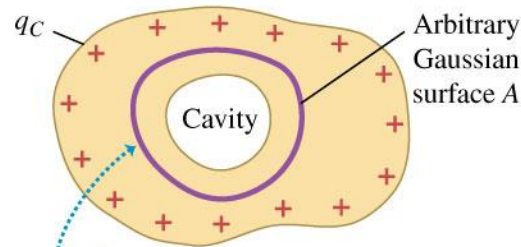

Because  $\vec{E} = 0$  at all points within the conductor, the electric field at all points on the Gaussian surface must be zero.

(c) An isolated charge  $q$  placed in the cavity

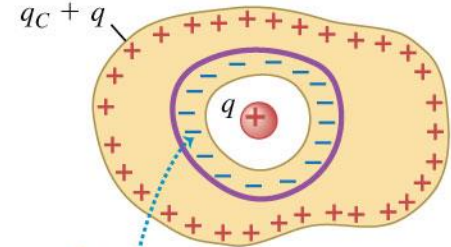

For  $\vec{E}$  to be zero at all points on the Gaussian surface, the surface of the cavity must have a total charge  $-q$ .

# A conductor with a cavity

- Follow Conceptual Example 22.11 using Figure 22.24 below.

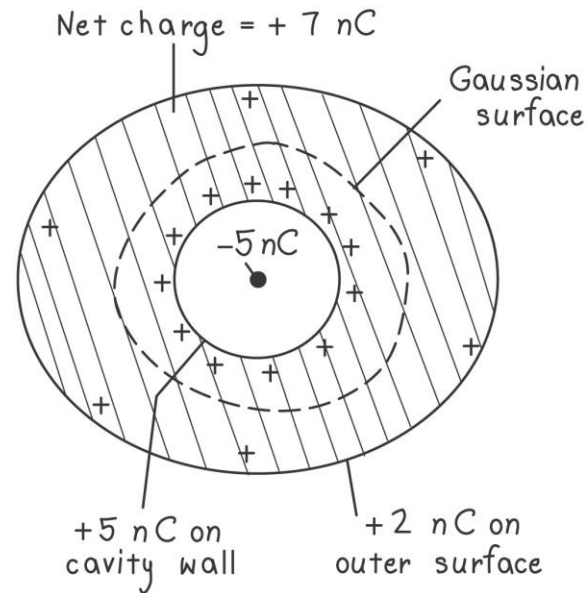

# Testing Gauss's law experimentally

- Follow the discussion of *Faraday's icepail experiment*, which confirmed the validity of Gauss's law. Use Figure 22.25 below.

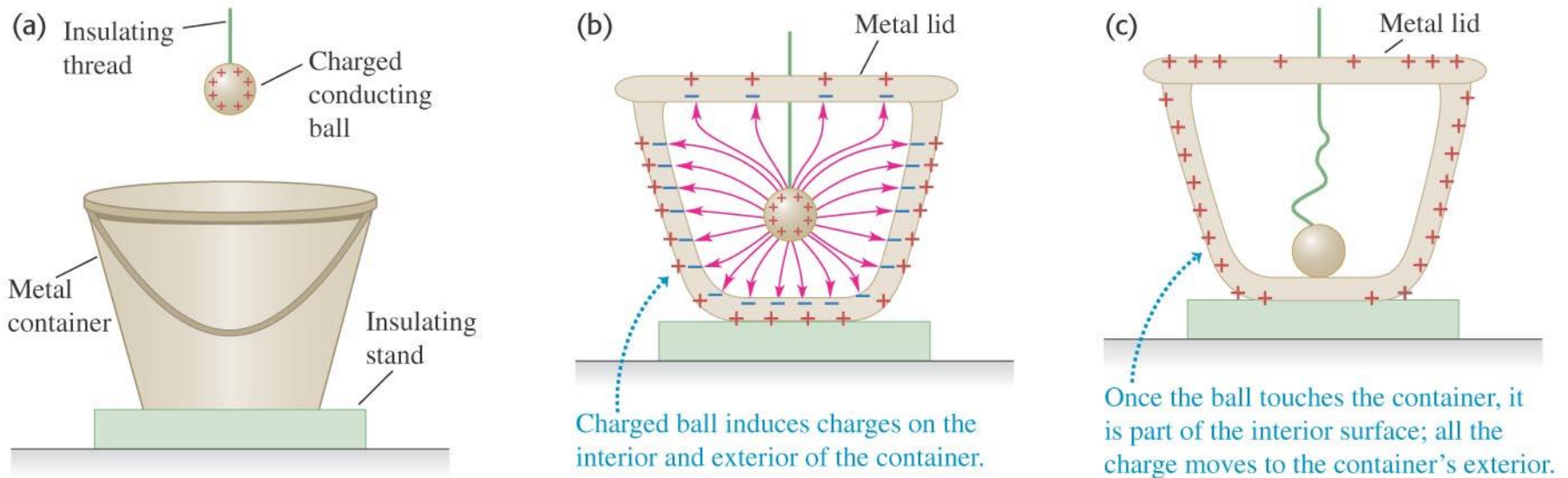

# The Van de Graaff generator

- The *Van de Graaff generator*, shown in Figure 22.26 below, operates on the same principle as in Faraday's icepail experiment.

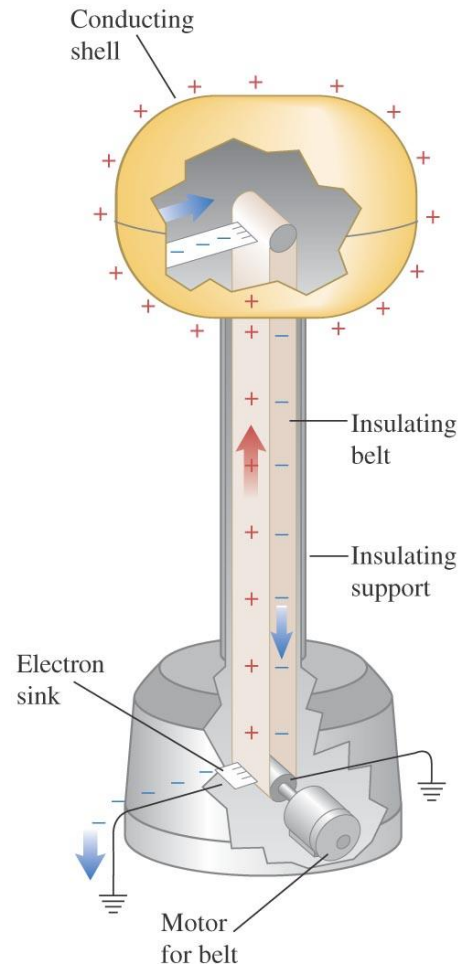



# Electrostatic shielding

- A conducting box (a *Faraday cage*) in an electric field shields the interior from the field. (See Figure 22.27 below.)

(a)

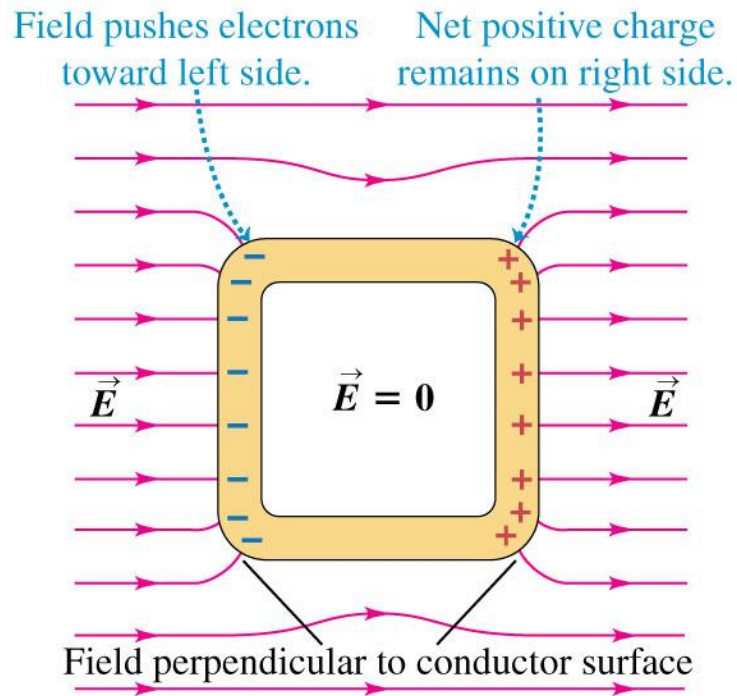

(b)



# Field at the surface of a conductor

- The electric field at the surface of any conductor is always perpendicular to the surface and has magnitude  $\sigma/\epsilon_0$ .
- Follow the discussion in the text, using Figure 22.28 at the right.
- Follow Conceptual Example 22.12.
- Follow Example 22.13, which deals with the electric field of the earth.

