

# Chapter 25

## Current, Resistance, and Electromotive Force

PowerPoint® Lectures for  
*University Physics, Thirteenth Edition*  
– *Hugh D. Young and Roger A. Freedman*

Lectures by Wayne Anderson

# Goals for Chapter 25

---

- To understand current and how charges move in a conductor
- To understand resistivity and conductivity
- To calculate the resistance of a conductor
- To learn how an emf causes current in a circuit
- To calculate energy and power in circuits

# Introduction

---

- Electric currents flow through light bulbs.
- Electric circuits contain charges in motion.
- Circuits are at the heart of modern devices such as computers, televisions, and industrial power systems.



# Current

- A *current* is any motion of charge from one region to another. Current is defined as  $I = dQ/dt$ .
- An electric field in a conductor causes charges to flow. (See Figure 25.1 at the right.)

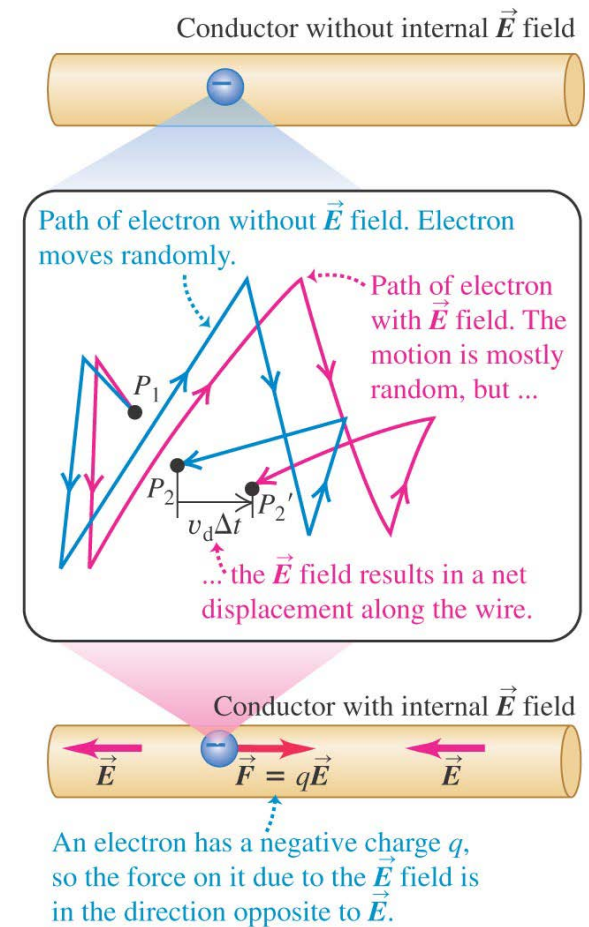

# Direction of current flow

- A current can be produced by positive or negative charge flow.
- *Conventional current* is treated as a flow of positive charges.
- The moving charges in metals are electrons (see figure below).

(a)

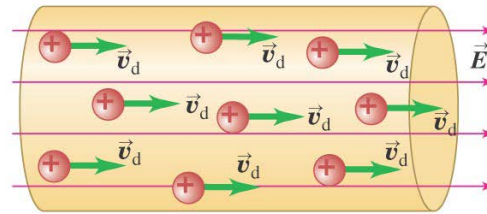

A **conventional current** is treated as a flow of positive charges, regardless of whether the free charges in the conductor are positive, negative, or both.

(b)

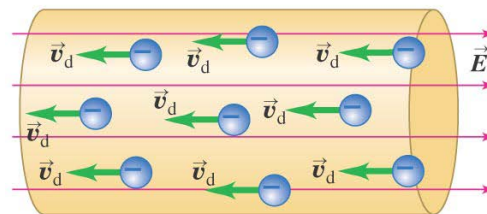

In a metallic conductor, the moving charges are electrons — but the *current* still points in the direction positive charges would flow.

# Current, drift velocity, and current density

- Follow the discussion of current, drift velocity, and current density.
- Figure 25.3 at the right shows the positive charges moving in the direction of the electric field.
- Follow Example 25.1.

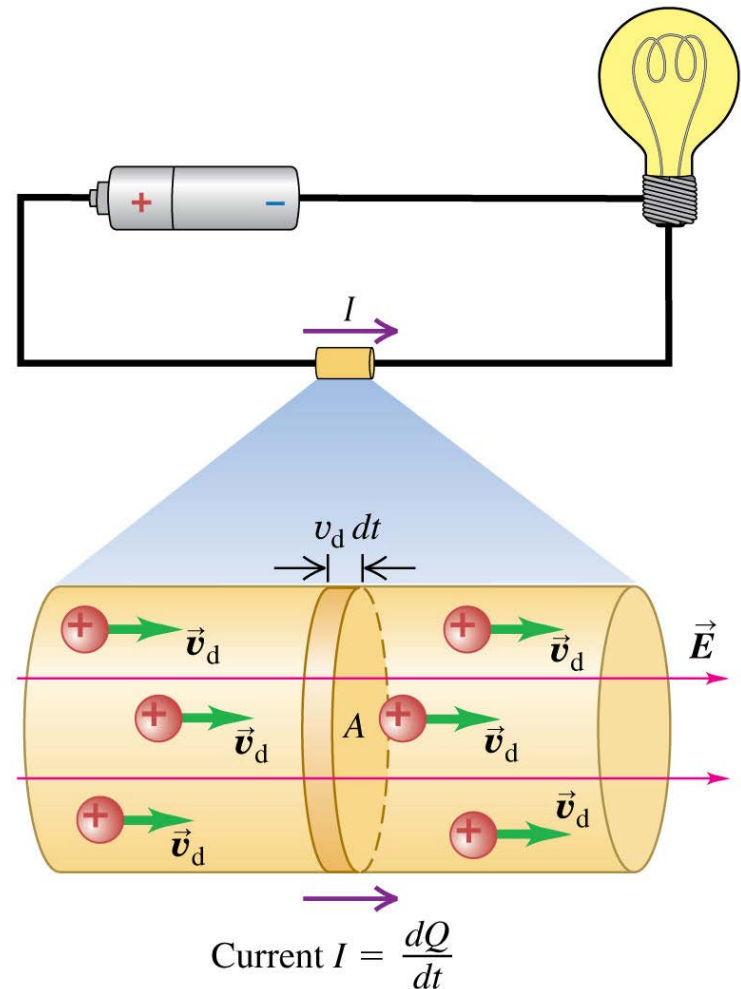

# Resistivity

- The *resistivity* of a material is the ratio of the electric field in the material to the current density it causes:  $\rho = E/J$ .
- The *conductivity* is the reciprocal of the resistivity.
- Table 25.1 shows the resistivity of various types of materials.

**Table 25.1** Resistivities at Room Temperature (20 °C)

Substance		$\rho$ ( $\Omega \cdot \text{m}$ )	Substance		$\rho$ ( $\Omega \cdot \text{m}$ )	
<b>Conductors</b>			<b>Semiconductors</b>			
Metals	Silver	$1.47 \times 10^{-8}$	Pure carbon (graphite)		$3.5 \times 10^{-5}$	
	Copper	$1.72 \times 10^{-8}$	Pure germanium		0.60	
	Gold	$2.44 \times 10^{-8}$	Pure silicon		2300	
	Aluminum	$2.75 \times 10^{-8}$	<b>Insulators</b>			
	Tungsten	$5.25 \times 10^{-8}$	Amber		$5 \times 10^{14}$	
	Steel	$20 \times 10^{-8}$	Glass		$10^{10}$ – $10^{14}$	
	Lead	$22 \times 10^{-8}$	Lucite		$>10^{13}$	
	Mercury	$95 \times 10^{-8}$	Mica		$10^{11}$ – $10^{15}$	
	Alloys	Manganin (Cu 84%, Mn 12%, Ni 4%)	$44 \times 10^{-8}$	Quartz (fused)		$75 \times 10^{16}$
		Constantan (Cu 60%, Ni 40%)	$49 \times 10^{-8}$	Sulfur		$10^{15}$
Nichrome		$100 \times 10^{-8}$	Teflon		$>10^{13}$	
			Wood		$10^8$ – $10^{11}$	

# Resistivity and temperature

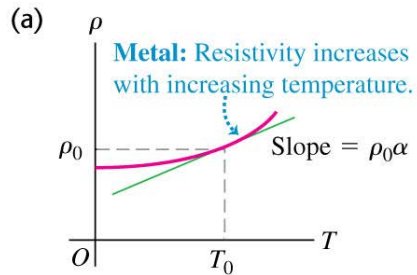

- Resistivity depends on temperature. See Figure 25.6 at the left.
- Table 25.2 shows some temperature coefficients of resistivity.

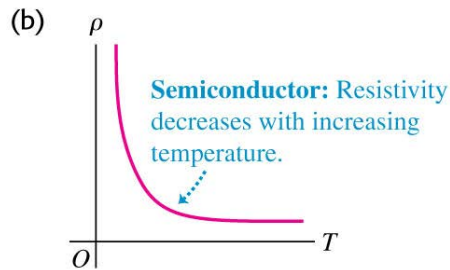

**Table 25.2** Temperature Coefficients of Resistivity (Approximate Values Near Room Temperature)

Material	$\alpha [(\text{°C})^{-1}]$	Material	$\alpha [(\text{°C})^{-1}]$
Aluminum	0.0039	Lead	0.0043
Brass	0.0020	Manganin	0.00000
Carbon (graphite)	-0.0005	Mercury	0.00088
Constantan	0.00001	Nichrome	0.0004
Copper	0.00393	Silver	0.0038
Iron	0.0050	Tungsten	0.0045

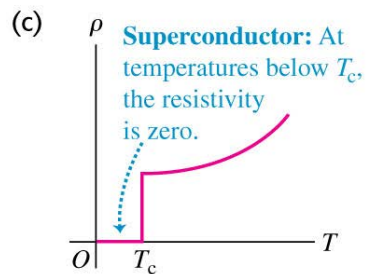



# Resistance

- The *resistance* of a conductor is  $R = \rho L/A$  (see Figure 25.7 below).
- The potential across a conductor is  $V = IR$ .
- If  $V$  is directly proportional to  $I$  (that is, if  $R$  is constant), the equation  $V = IR$  is called *Ohm's law*.

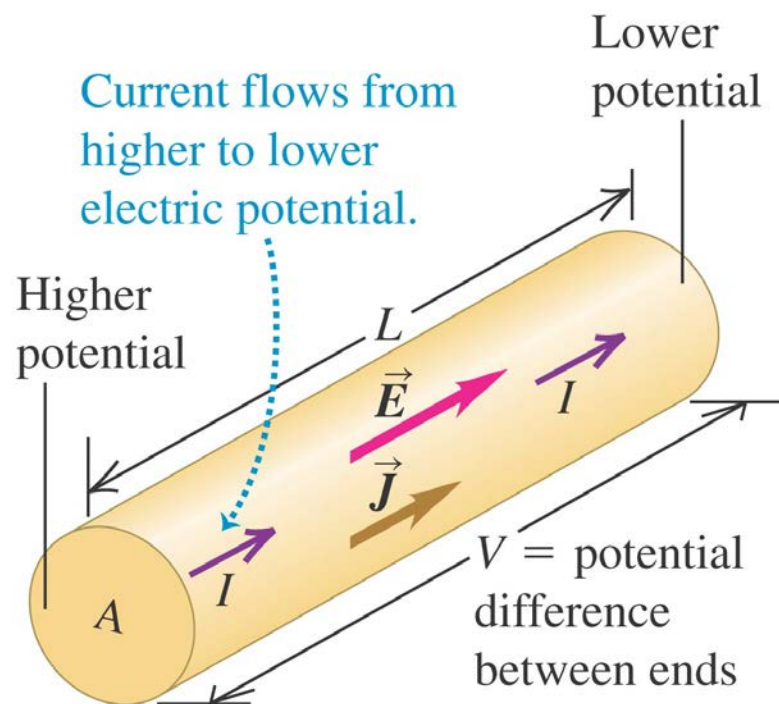

# Resistors are color-coded for easy identification

- This resistor has a resistance of 5.7 k $\Omega$  with a tolerance of  $\pm 10\%$ .

**Table 25.3** Color Codes for Resistors

Color	Value as Digit	Value as Multiplier
Black	0	1
Brown	1	10
Red	2	10 <sup>2</sup>
Orange	3	10 <sup>3</sup>
Yellow	4	10 <sup>4</sup>
Green	5	10 <sup>5</sup>
Blue	6	10 <sup>6</sup>
Violet	7	10 <sup>7</sup>
Gray	8	10 <sup>8</sup>
White	9	10 <sup>9</sup>

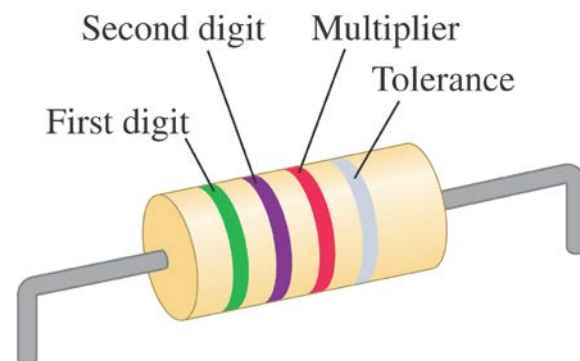

# Ohmic and nonohmic resistors

- Only the resistor in Figure 25.10(a) below obeys Ohm's law.
- Follow Example 25.2.
- Follow Example 25.3.

(a)

**Ohmic resistor** (e.g., typical metal wire): At a given temperature, current is proportional to voltage.

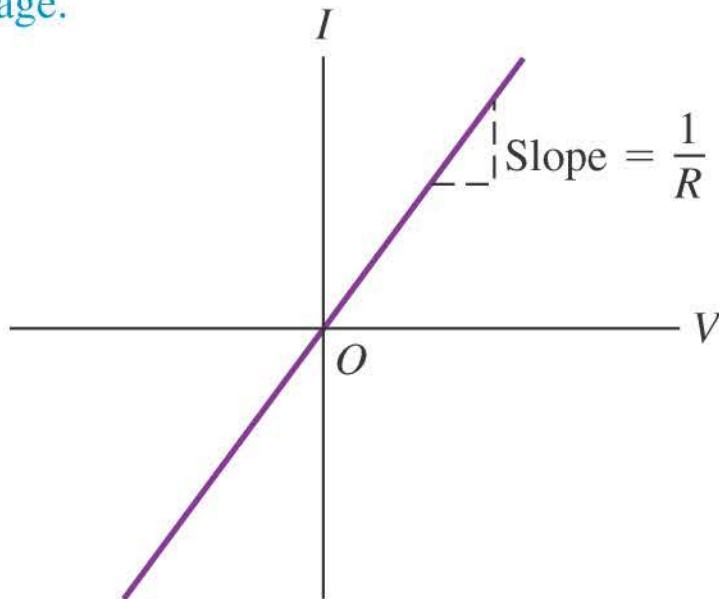

(b)

**Semiconductor diode: a nonohmic resistor**

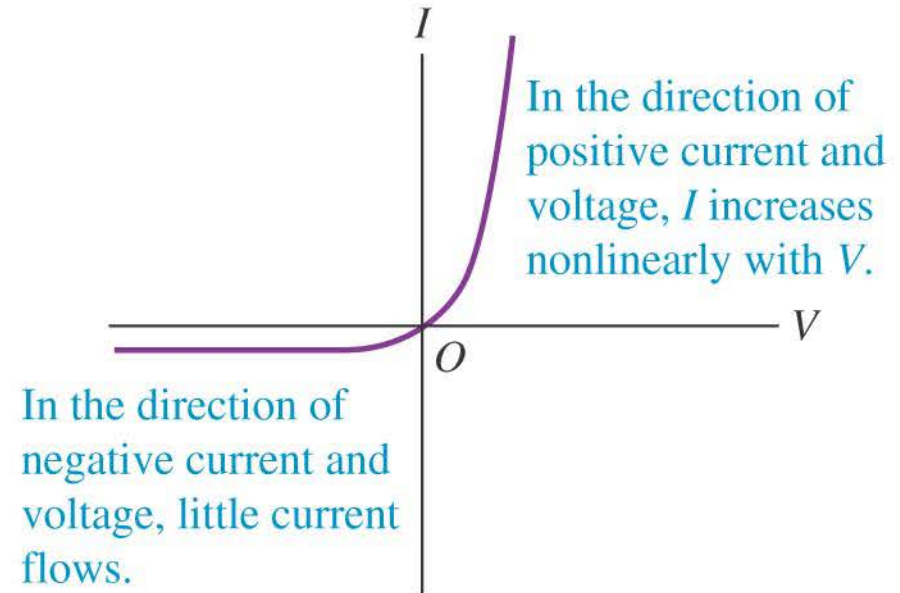

# Electromotive force and circuits

- An *electromotive force (emf)* makes current flow. In spite of the name, an emf is *not* a force.
- The figures below show a source of emf in an open circuit (left) and in a complete circuit (right).

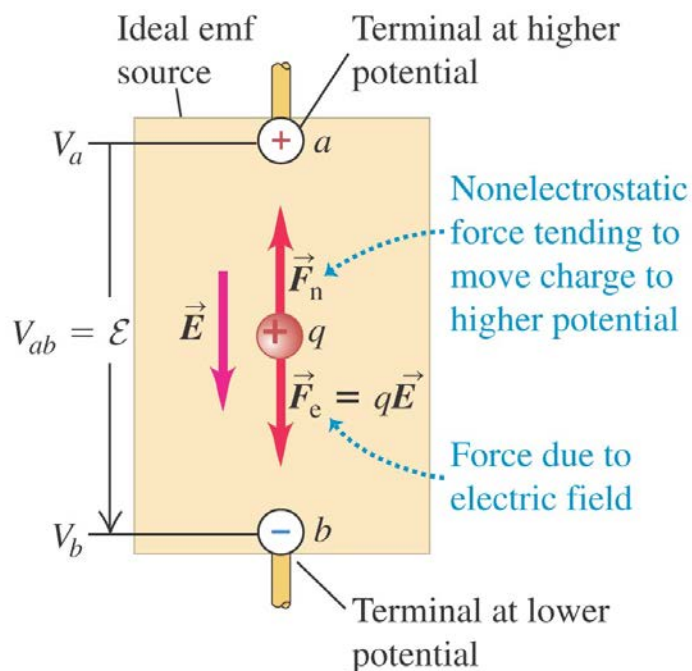

When the emf source is not part of a closed circuit,  $F_n = F_e$  and there is no net motion of charge between the terminals.

Potential across terminals creates electric field in circuit, causing charges to move.

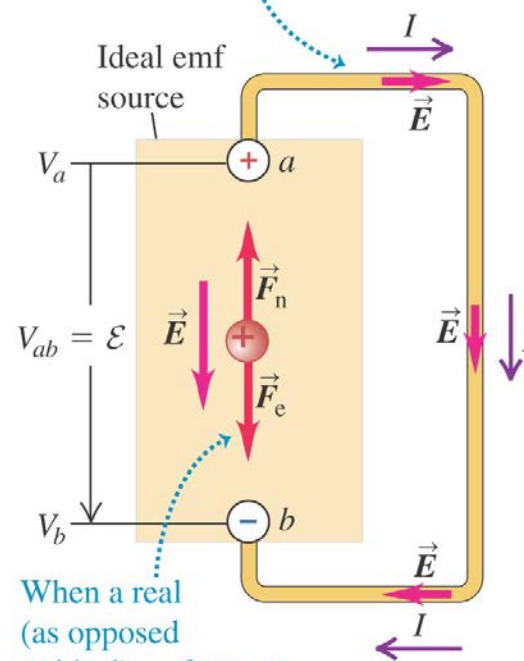

When a real (as opposed to ideal) emf source is connected to a circuit,  $V_{ab}$  and thus  $F_e$  fall, so that  $F_n > F_e$  and  $F_n$  does work on the charges.

# Internal resistance



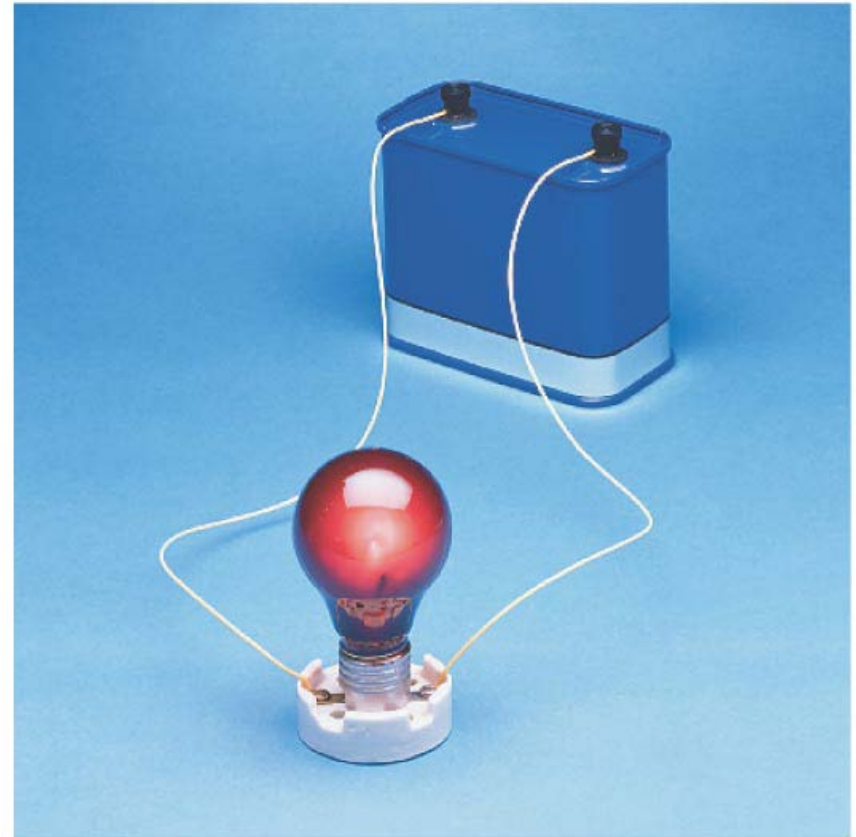

- Real sources of emf actually contain some *internal resistance*  $r$ .
- The *terminal voltage* of an emf source is  $V_{ab} = \xi - Ir$ .
- The terminal voltage of the 12-V battery shown at the right is less than 12 V when it is connected to the light bulb.



# Symbols for circuit diagrams

- Table 25.4 shows the usual symbols used in circuit diagrams.

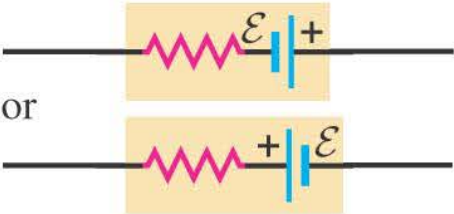
**Table 25.4** Symbols for Circuit Diagrams

	Conductor with negligible resistance
	Resistor
	Source of emf (longer vertical line always represents the positive terminal, usually the terminal with higher potential)
	Source of emf with internal resistance $r$ ( $r$ can be placed on either side)
	Voltmeter (measures potential difference between its terminals)
	Ammeter (measures current through it)

# A source in an open circuit

- Follow Conceptual Example 25.4 using Figure 25.16 below.

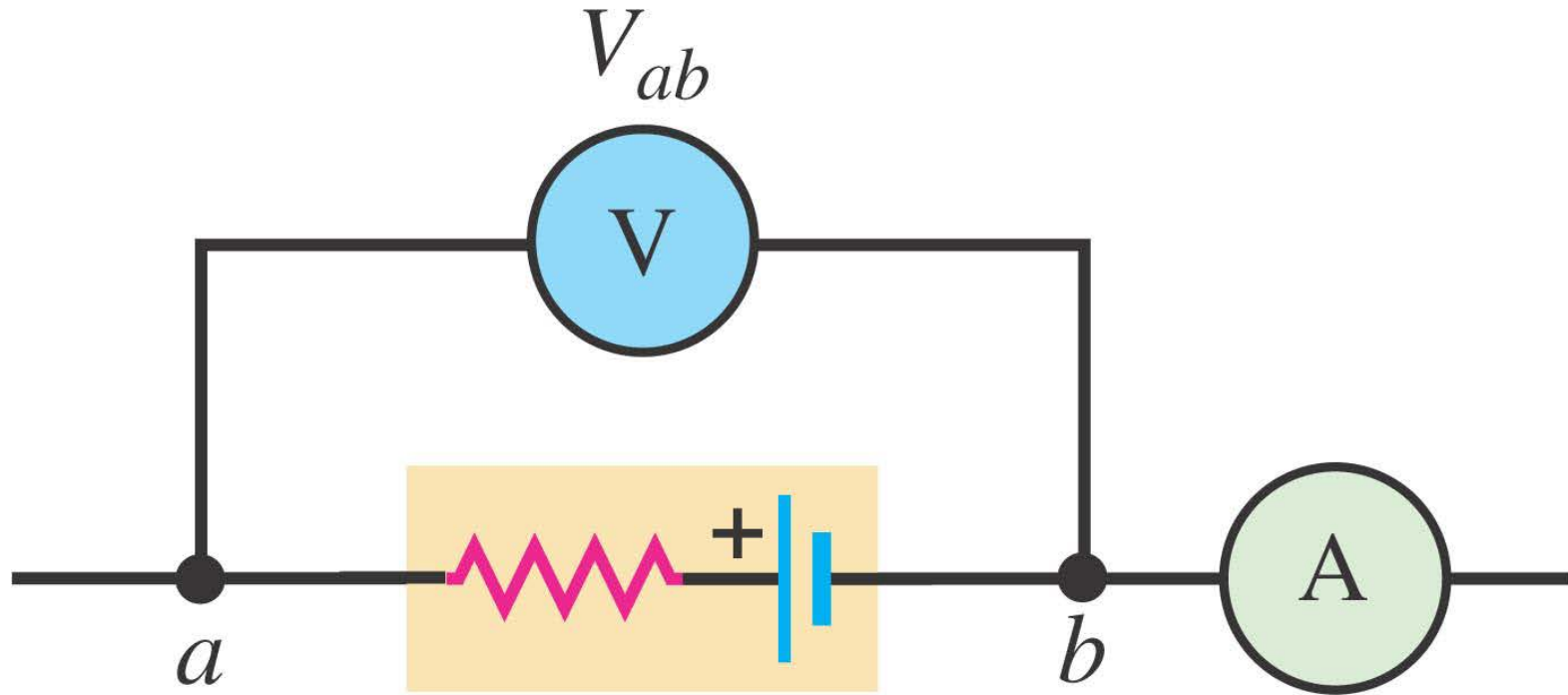

$$r = 2 \Omega, \mathcal{E} = 12 \text{ V}$$

# Source in a complete circuit

- Follow Example 25.5 using Figure 25.17 below.

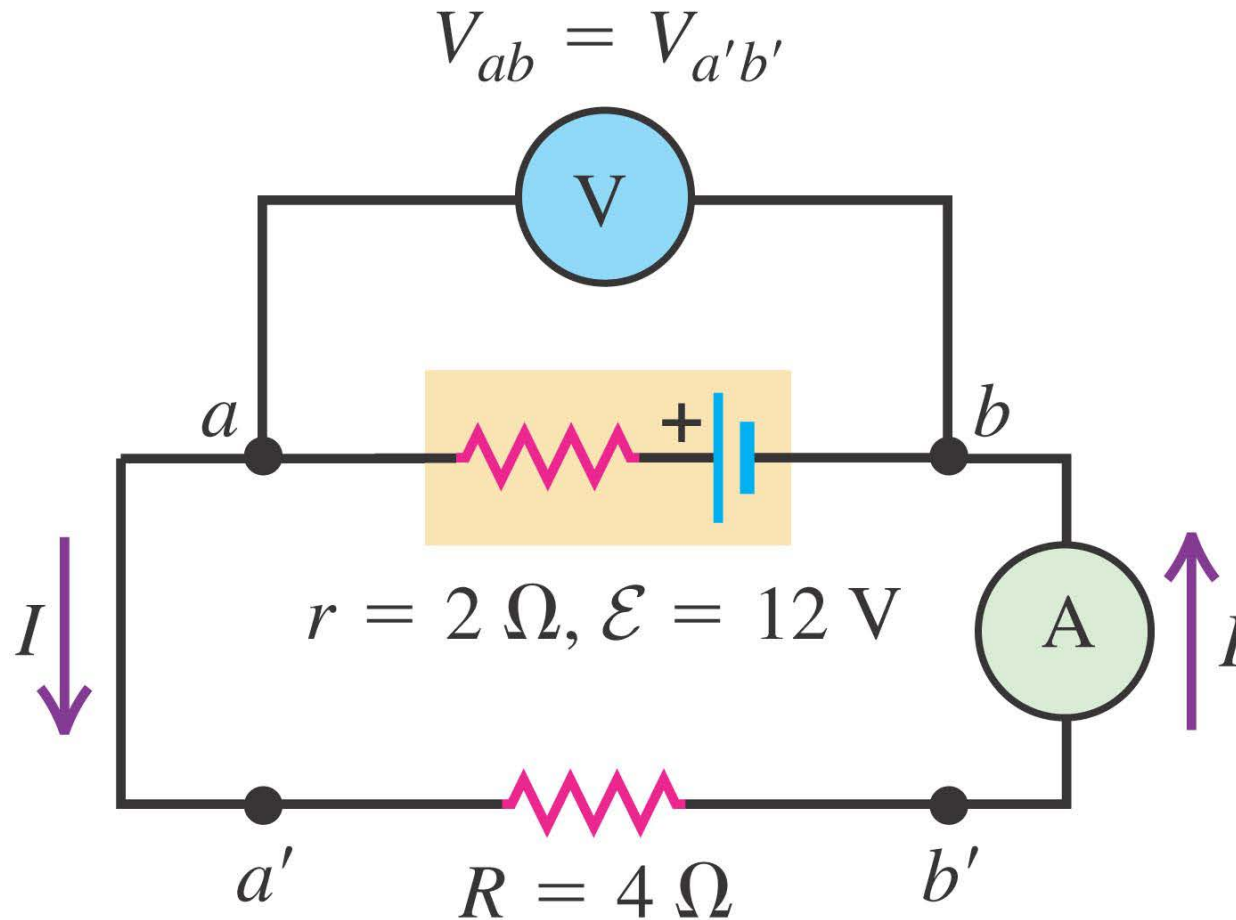



# Using voltmeters and ammeters

- Follow Conceptual Example 25.6 using Figure 25.18 (below), in which the meters of the previous circuit have been moved.

(a)

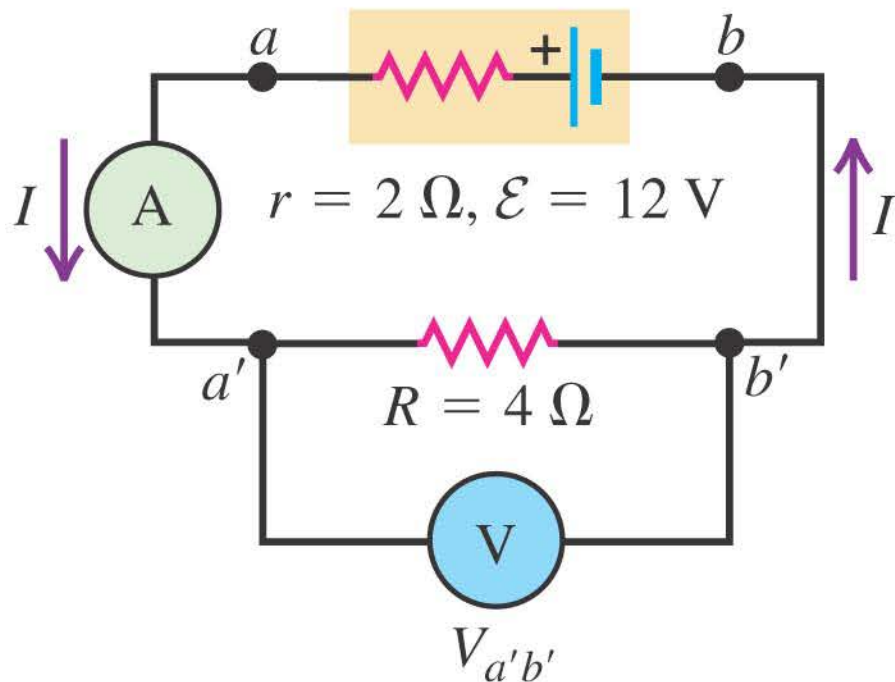

(b)

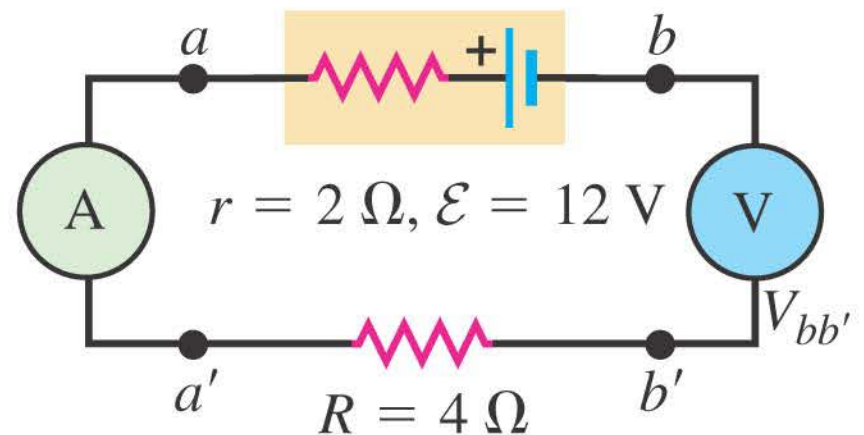

## A source with a short circuit

- Follow Example 25.7 using Figure 25.19 below.

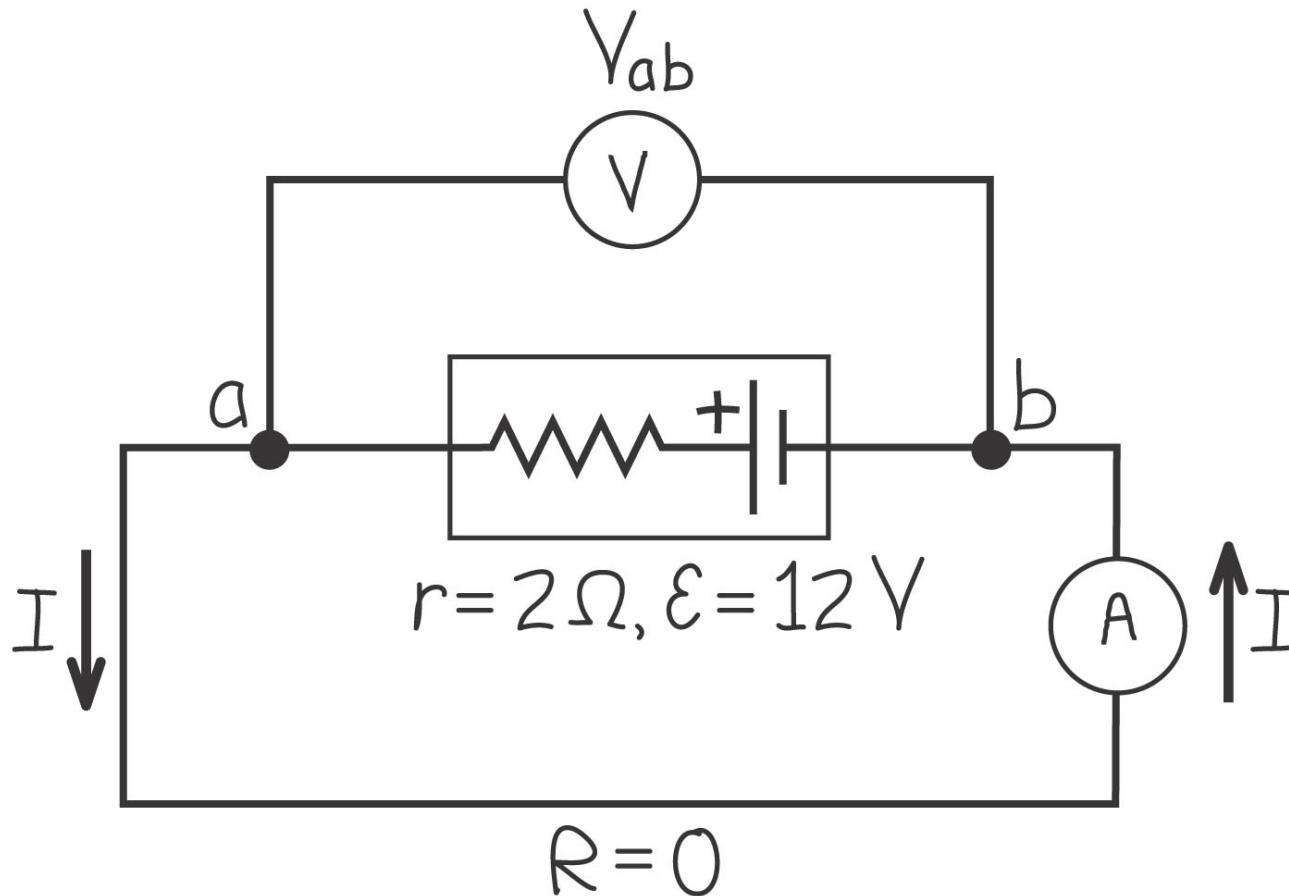

# Potential changes around a circuit

- The net change in potential must be zero for a round trip in a circuit.
- Follow Figure 25.20 at the right.

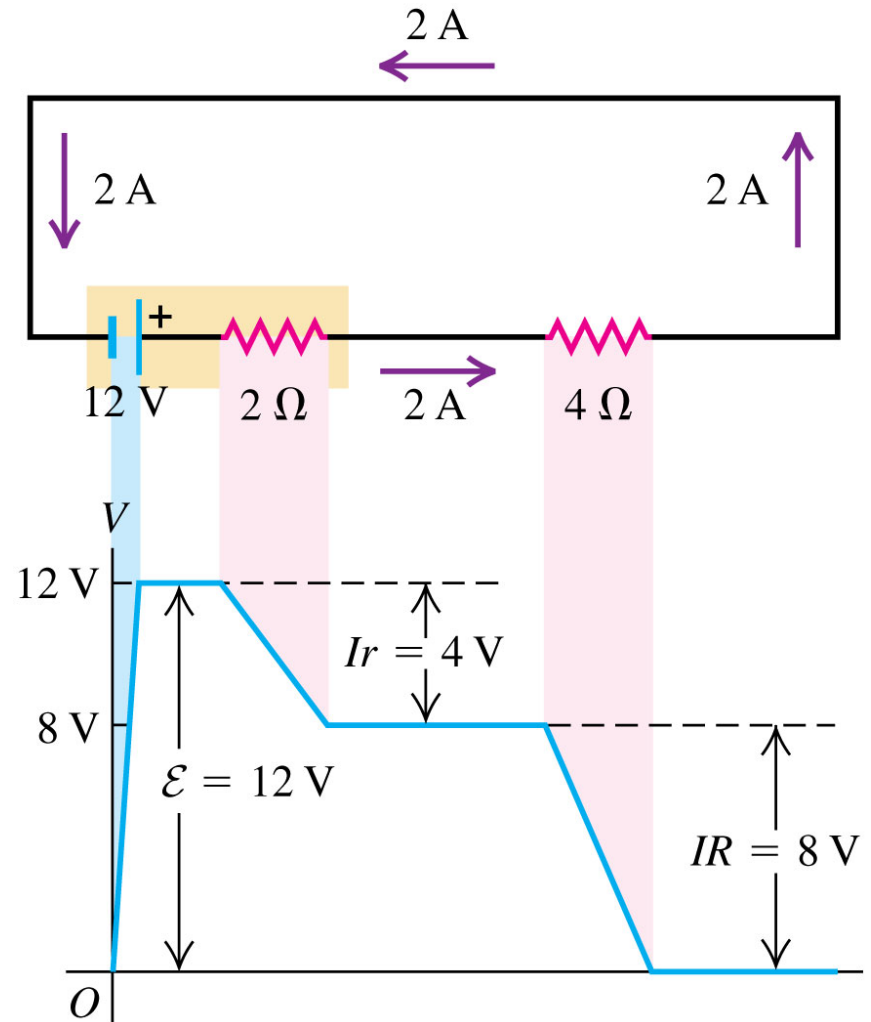

# Energy and power in electric circuits

- The rate at which energy is delivered to (or extracted from) a circuit element is  $P = V_{ab}I$ . See Figures 25.21 (below) and 25.22 (at right).
- The power delivered to a pure resistor is  $P = I^2R = V_{ab}^2/R$ .

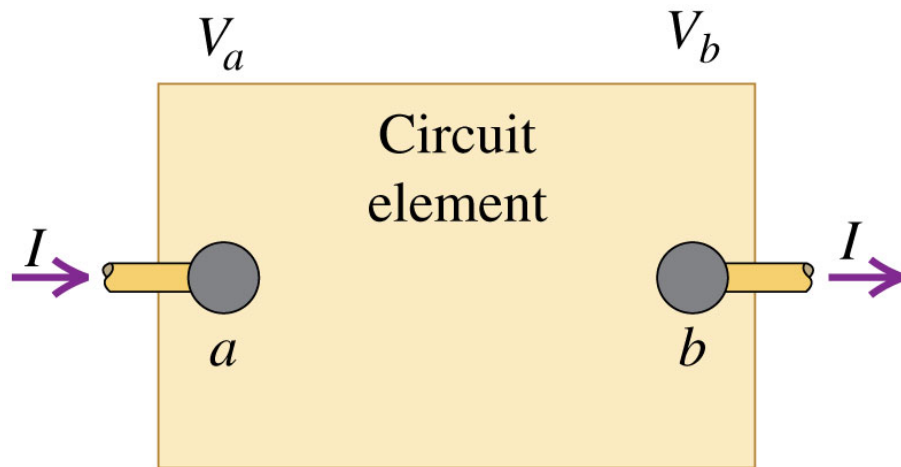

(a) Diagrammatic circuit

- The emf source converts nonelectrical to electrical energy at a rate  $\mathcal{E}I$ .
- Its internal resistance *dissipates* energy at a rate  $I^2r$ .
- The difference  $\mathcal{E}I - I^2r$  is its power output.

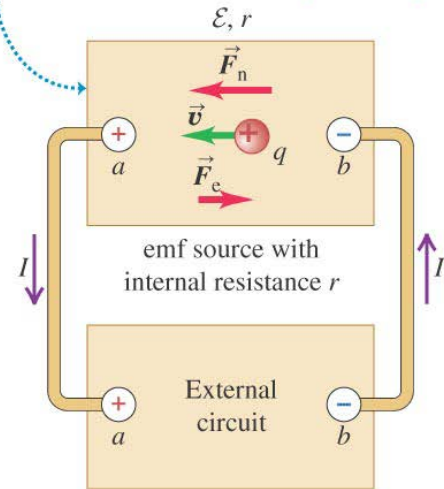

(b) A real circuit of the type shown in (a)

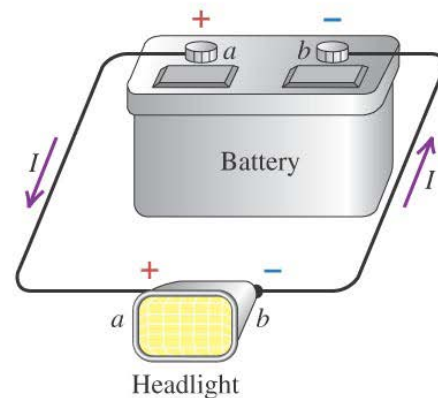

# Power input and output

- Read Problem-Solving Strategy 25.1.
- Follow Example 25.8, using Figure 25.24 below.
- Follow Example 25.9 in which we have doubled the  $4\text{-}\Omega$  resistor of the previous example.

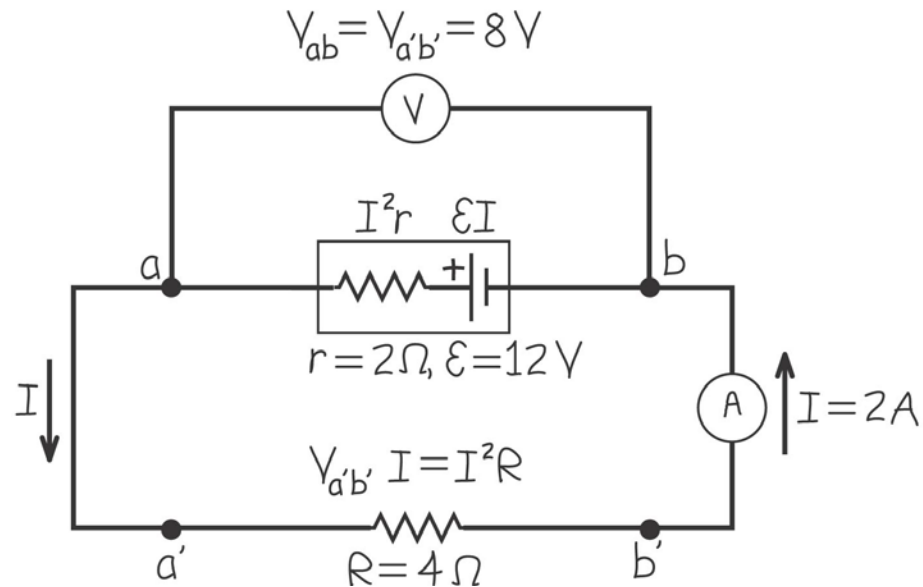

# Power in a short circuit

- Follow Example 25.10, using Figure 25.25 below.

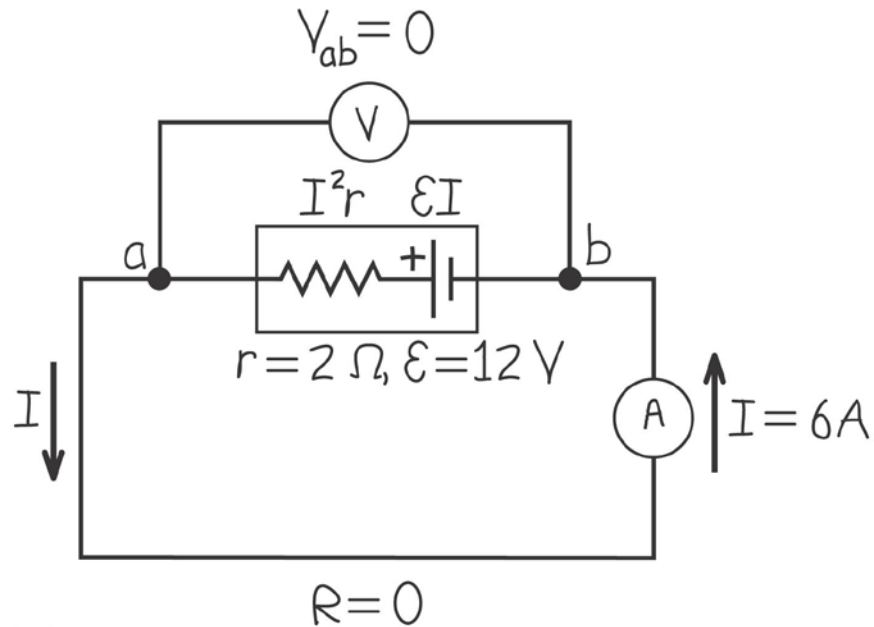

# Theory of metallic conduction

- Follow the discussion in the text using Figures 25.26 (right) and 25.27 (below). Both illustrate the random motion of electrons in a conductor.
- Follow Example 25.11.

